

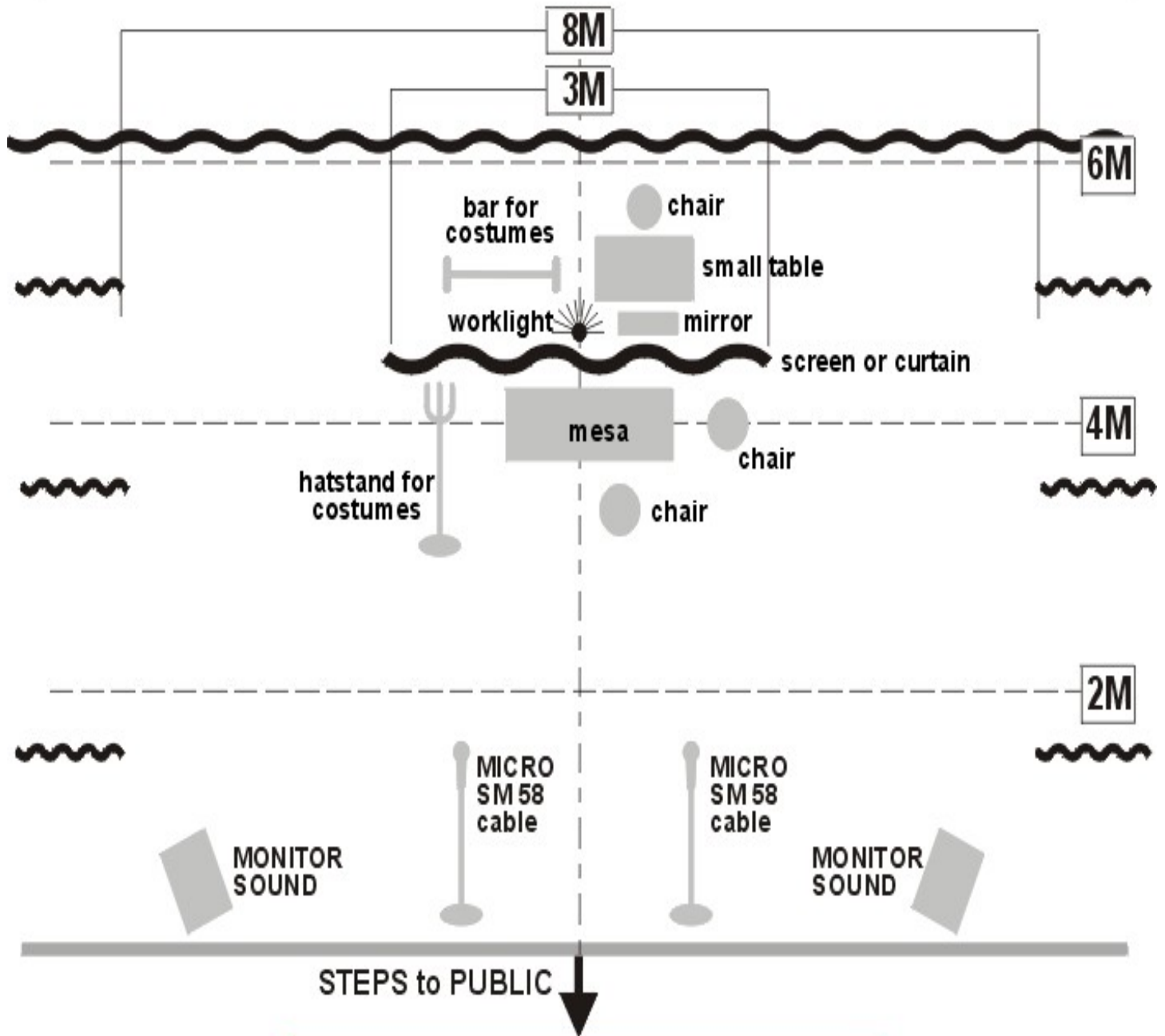

# Stage Plan

## JANGO Classics Duo



### SOUND LIST:

- 2 Radio Head Micros (Jango + Peter)
- 2 Micros with cable (SM 58)
- 2 Mike Stands with round weighted base
- 2 Stage Monitors (seperate mix)
- 1 C.D Player

# Light Plan

## JANGO Classics Duo

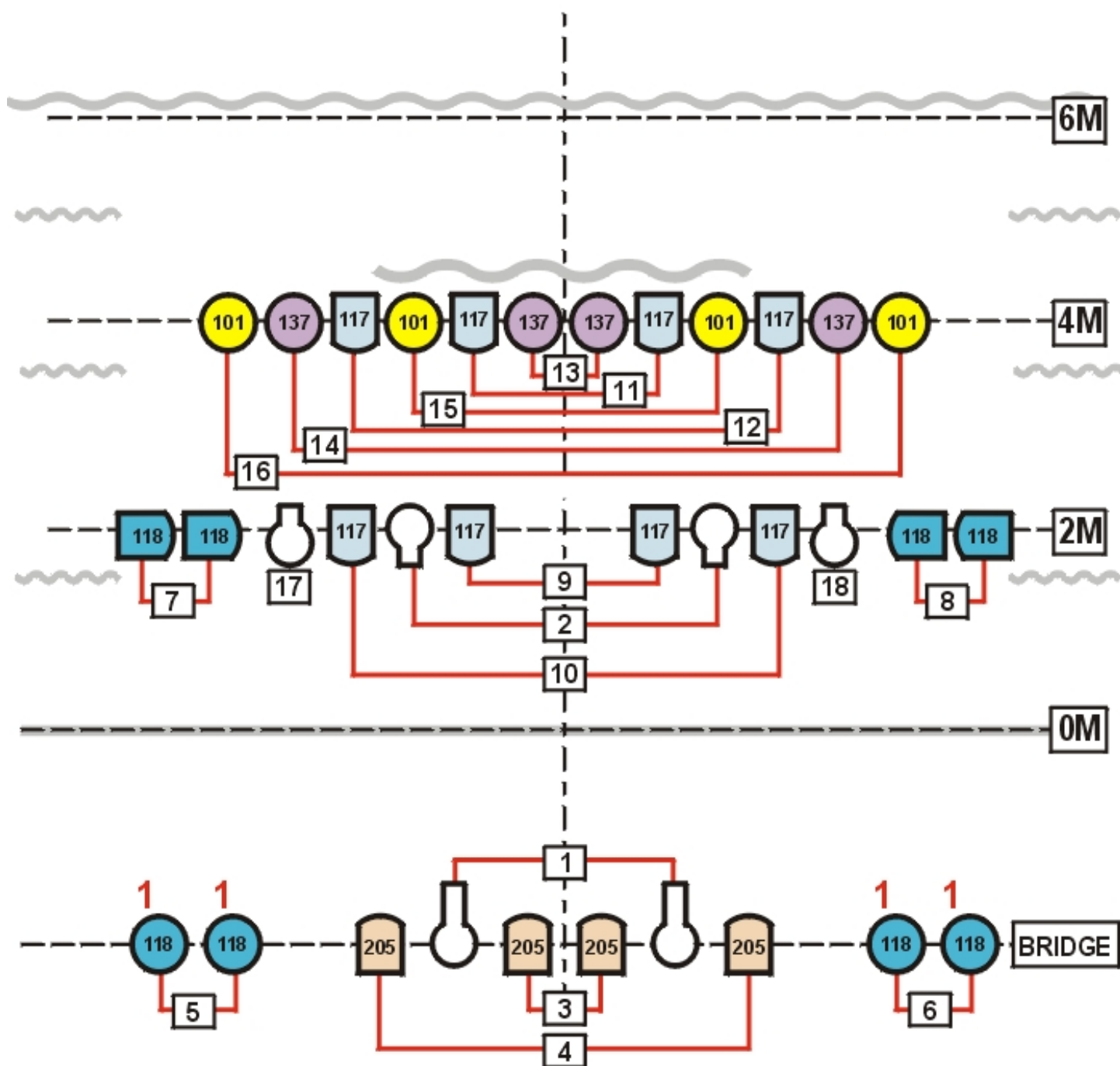

-  1000w PROFILE long x 2
-  1000w PROFILE short x 4
-  1000w PAR x 12
-  1000w P.C. x 16

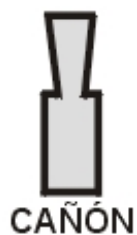

-  'LEE' FILTER Nr.
- CHANNEL Nr.
- 101 YELLOW
- 117 STEEL BLUE
- 118 LIGHT BLUE
- 137 SPECIAL LAVENDER
- 205 ½ C.T. ORANGE

TOTAL LIGHTS 34  
TOTAL CHANNELS 18